

SPIRAL duct boxes

# WOOD-BOX-IPPC



## Description

The boxes are designed for transporting SPIRAL round ventilation DUCTS. They are used for diameters from 80 to 315 mm, which, to save space, can be inserted smaller into a larger one up to a maximum of 3 diameters. The box is made of fumigated wood giving the possibility of sea transport. It is possible to stack the boxes on top of each other..

### Product code example

Product code: **WOOD-BOX-IPPC**

type \_\_\_\_\_

## Dimensions

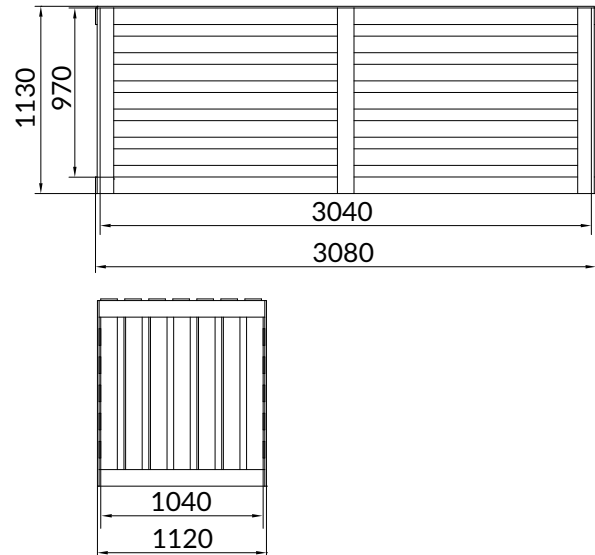

SPIRAL duct boxes

# WOOD-BOX-3020

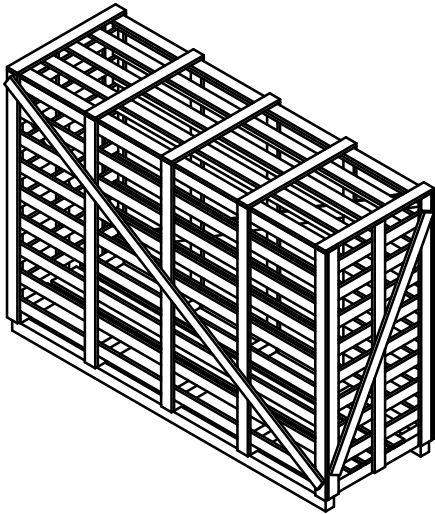

## Description

The boxes are designed for transporting SPIRAL round ventilation DUCTs. They are used for diameters from 80 to 250 mm, which, to save space, can be inserted smaller into a larger one up to a maximum of 3 diameters. The box is made of fumigated wood giving the possibility of sea transport.

### Product code example

Product code: **WOOD-BOX-3020**

type \_\_\_\_\_

## Dimensions

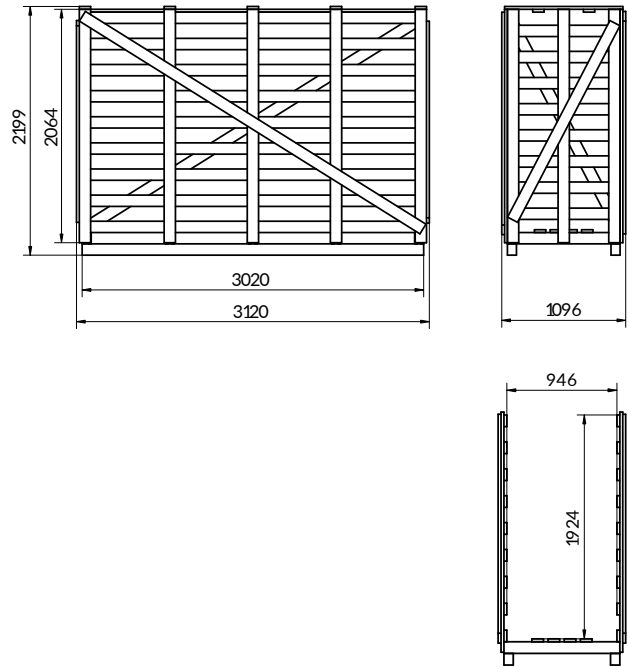

SPIRAL duct boxes

# WOOD-BOX-3000

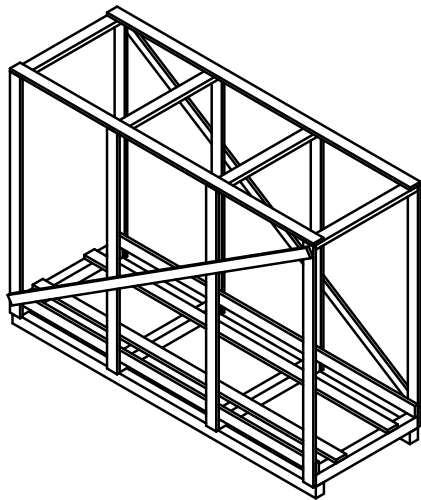

## Description

The boxes are designed for transporting SPIRAL round ventilation DUCTs. They are used for diameters from 80 to 250 mm, which, to save space, can be inserted smaller into a larger one up to a maximum of 3 diameters. The box is made of fumigated wood giving the possibility of sea transport.

### Product code example

Product code: **WOOD-BOX-3000**

type \_\_\_\_\_

## Dimensions

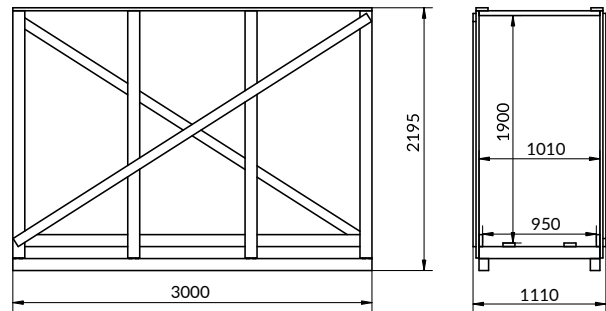

SPIRAL duct boxes

# WOOD-FRAME-1200-1130

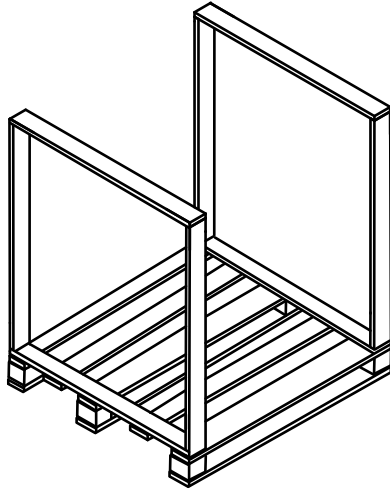

## Description

Wooden frames are designed for transporting SPIRAL round ventilation DUCTS. They are used for various diameters. To save space, they can be stacked on top of each other.

### Product code example

Product code: **WOOD-BOX-1200-1130**

type \_\_\_\_\_

## Dimensions

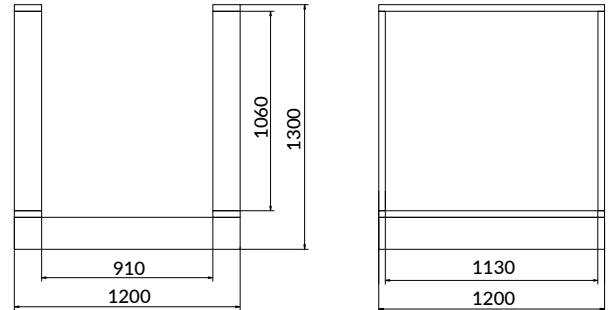

SPIRAL duct boxes

# WOOD-BOX-D

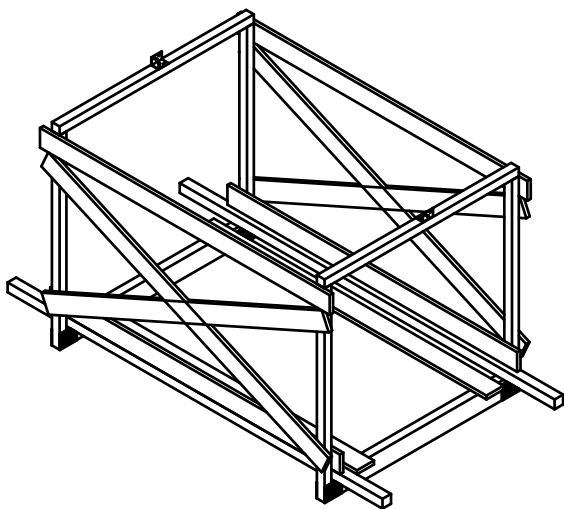

## Description

The boxes are designed for transporting SPIRAL round ventilation DUCTS. They are used for various diameters which, to save space, can be inserted smaller into a larger one up to a maximum of 3 diameters. It is possible to stack the boxes

### Product code example

Product code: **WOOD-BOX-D**

type \_\_\_\_\_

## Dimensions

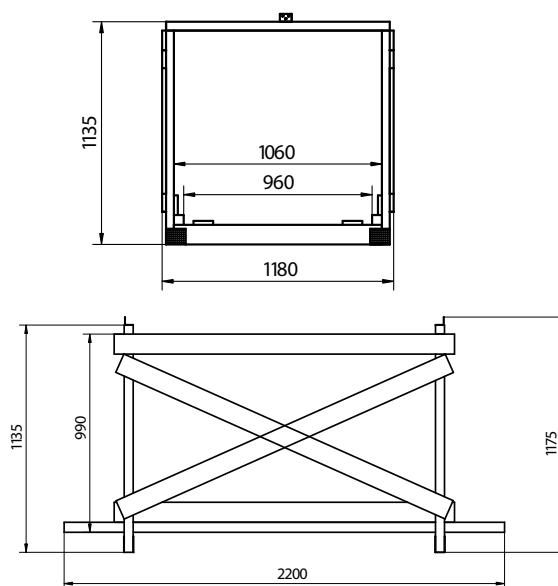

SPIRAL duct boxes

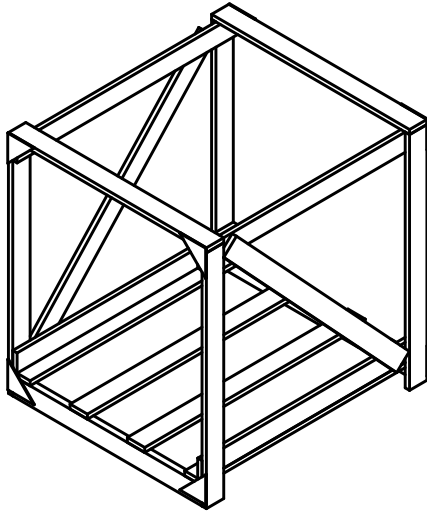
**WOOD-BOX-127-118-131****Description**

The boxes are designed for transporting SPIRAL round ventilation DUCTS. They are used for various diameters

**Product code example**

Product code: **WOOD-BOX-127-118-131**

type \_\_\_\_\_

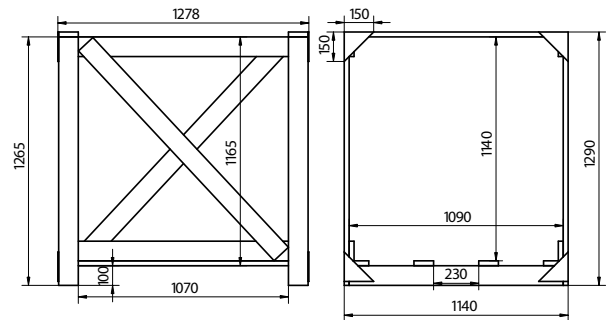
**Dimensions**

SPIRAL duct boxes

# WOOD-BOX-203-111-120

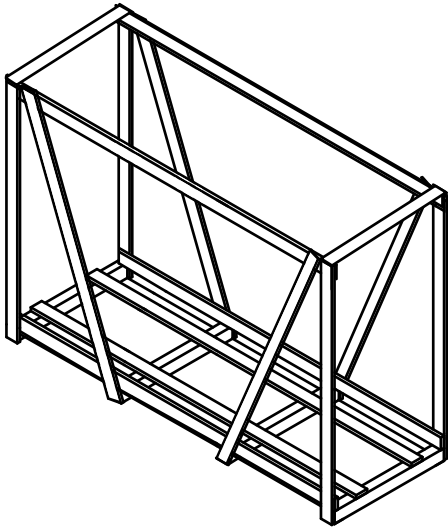

## Description

The crates are designed for transporting SPIRAL round ventilation pipes. They are used for diameters from 80 mm to 315 mm. Thanks to their durable construction, it is possible to stack one crate on top of another.

### Product code example

Product code: **WOOD-BOX-203-111-120**

type \_\_\_\_\_

## Dimensions

